

## IN-VEHICLE REPAIR

### Timing Drive Components

#### Removal

**⚠ CAUTION:** Failure to verify correct timing drive component alignment will result in severe engine damage.

1. Remove the engine front cover. For additional information, refer to Engine Front Cover in this section.

2. **⚠ CAUTION:** This pulse wheel is used with several different engines. Install the pulse wheel with the keyway in the slot stamped “30” or “30 RFF” only (orange in color).

Remove the ignition pulse wheel.

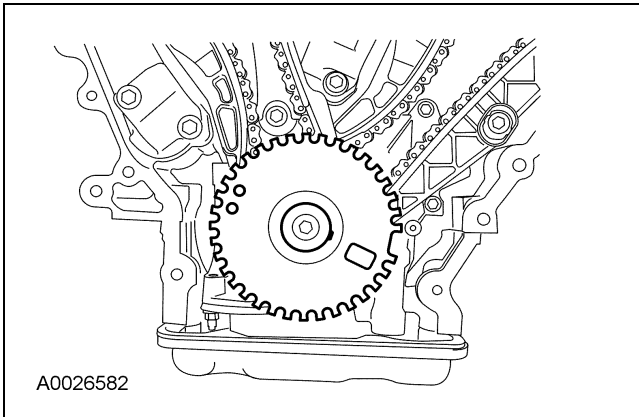

3. Install the damper bolt.

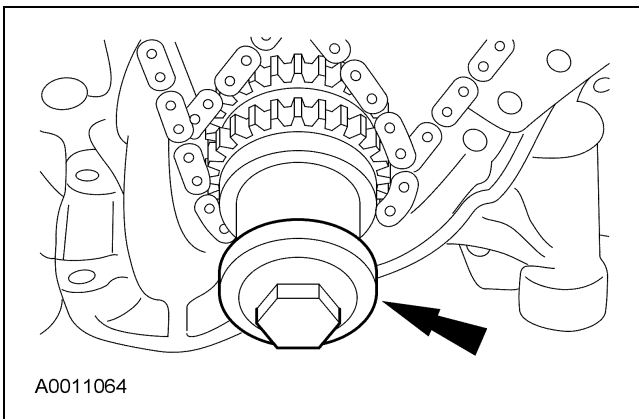

4. **NOTE:** LH shown, RH similar.  
Remove the LH and RH spark plugs.

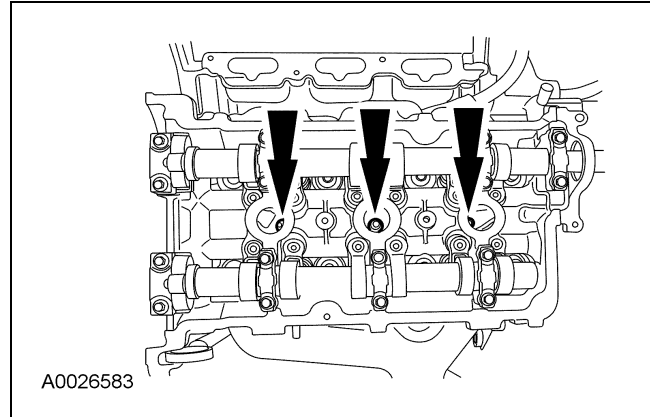

5. Rotate the crankshaft clockwise to position the crankshaft keyway in the 11 o'clock position and position the camshafts in the correct position. This will position the number one cylinder at top dead center (TDC).
  - Verify that the camshafts are correctly located. If not, rotate the crankshaft one additional turn and recheck.

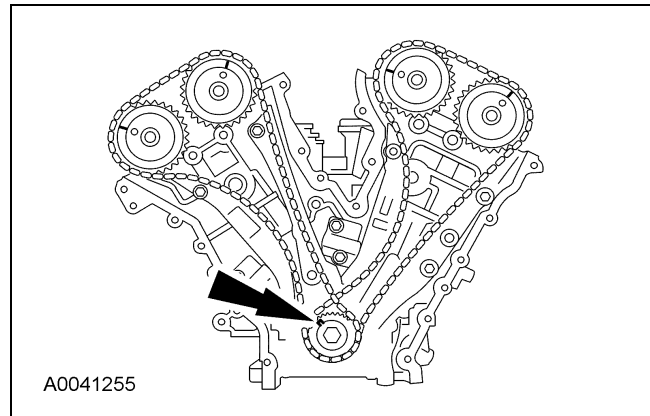

6. Rotate the crankshaft clockwise 120 degrees to the 3 o'clock position to locate the RH camshafts in the neutral position.

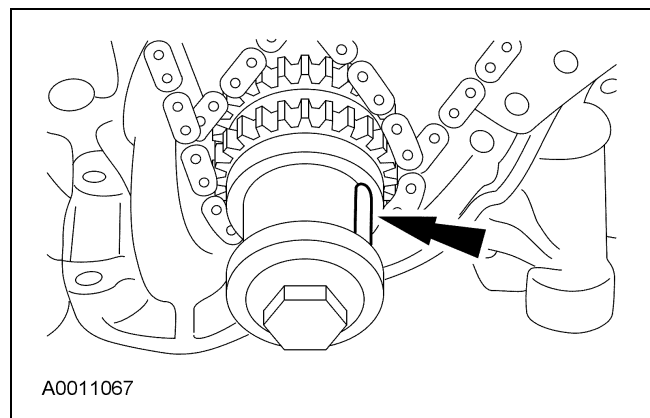

**IN-VEHICLE REPAIR (Continued)**

7. Verify that the RH camshafts are in the neutral position.

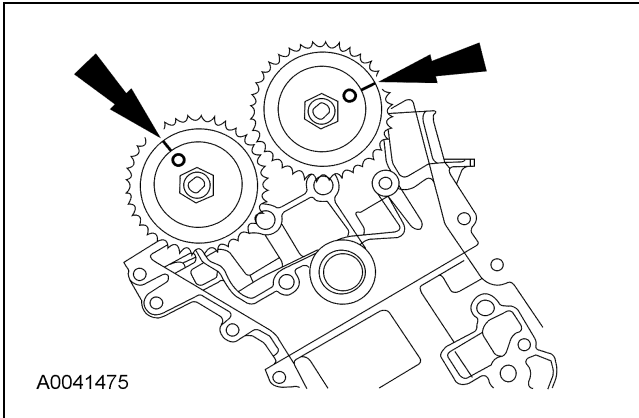

8. Remove the RH timing chain tensioner arm.
- 1 Remove the bolts.
  - 2 Remove the tensioner.
  - 3 Remove the tensioner arm.

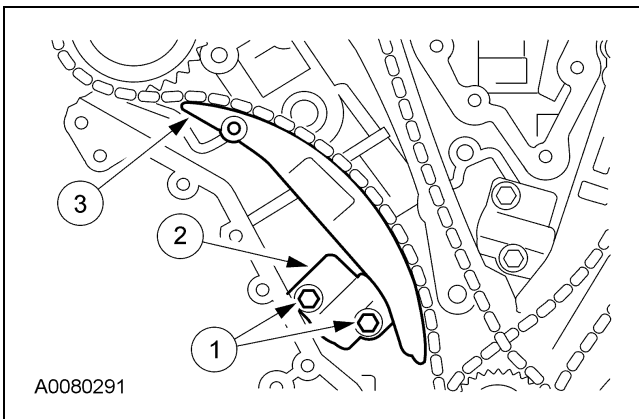

9. Remove the bolts, RH timing chain guide and the timing chain.

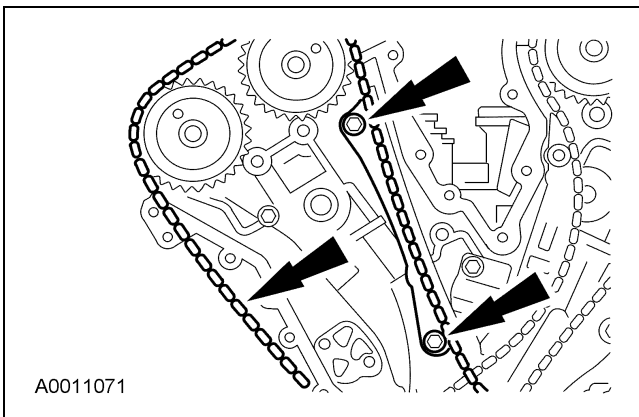

10. Rotate the crankshaft clockwise 600 degrees (1-2/3 turns) to position the crankshaft keyway in the 11 o'clock position. This will position the LH camshafts in the neutral position.

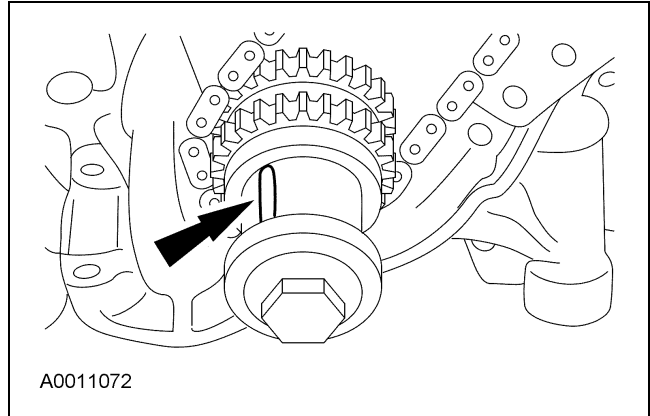

11. Verify that the LH camshafts are in the neutral position.

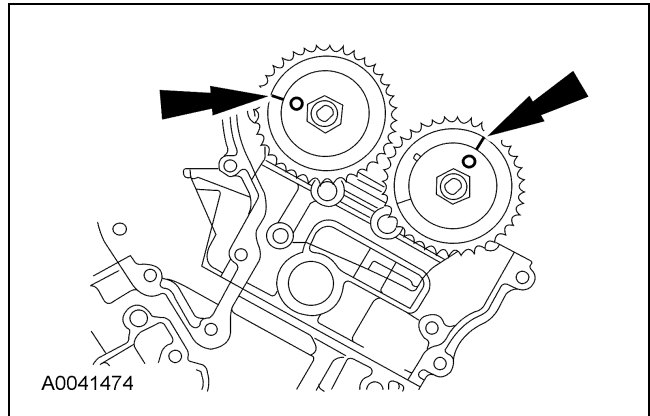

12. Remove the LH timing chain and tensioner arm.
- 1 Remove the bolts.
  - 2 Remove the tensioner.
  - 3 Remove the tensioner arm.

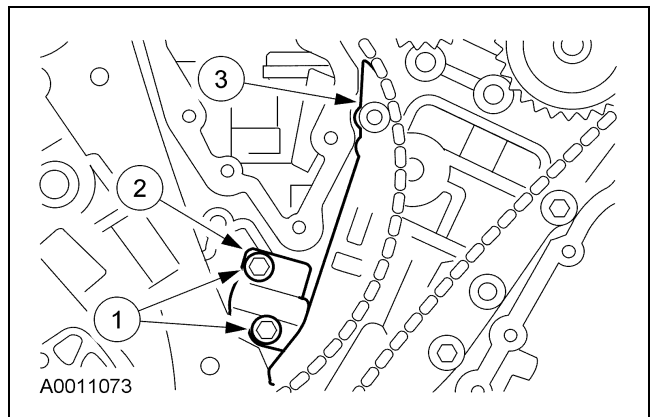

**IN-VEHICLE REPAIR (Continued)**

13. Remove the LH timing chain and timing chain guide.

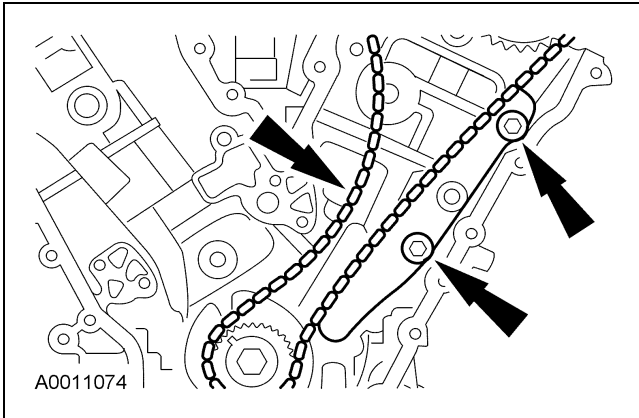

14. Remove the damper bolt and the crankshaft sprockets.

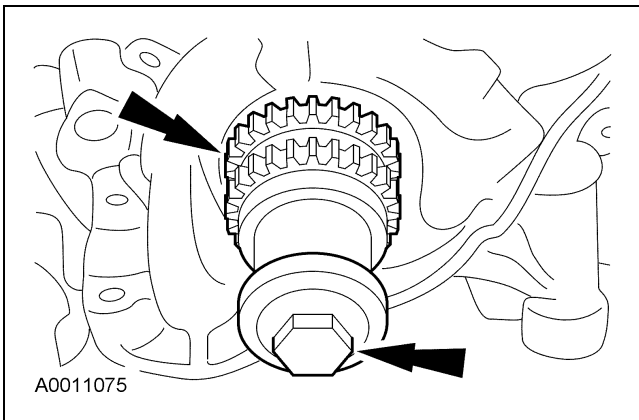
**Installation**

**⚠ CAUTION:** Failure to verify correct timing drive component alignment will result in severe engine damage.

- NOTE:** Install the sprockets with the timing marks facing outward.  
Install the crankshaft sprockets.

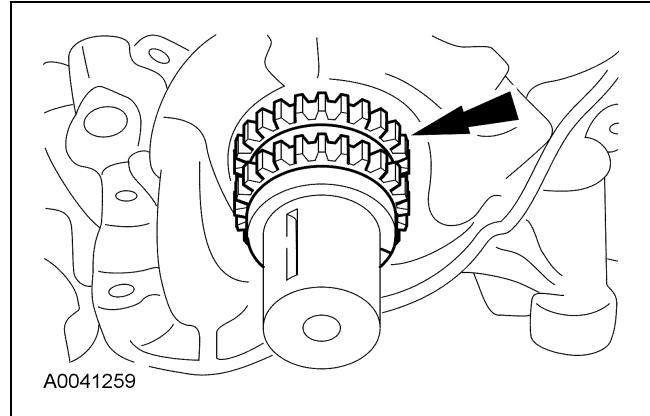

- NOTE:** LH shown, RH similar.  
Position the chain tensioner in a soft-jawed vise.

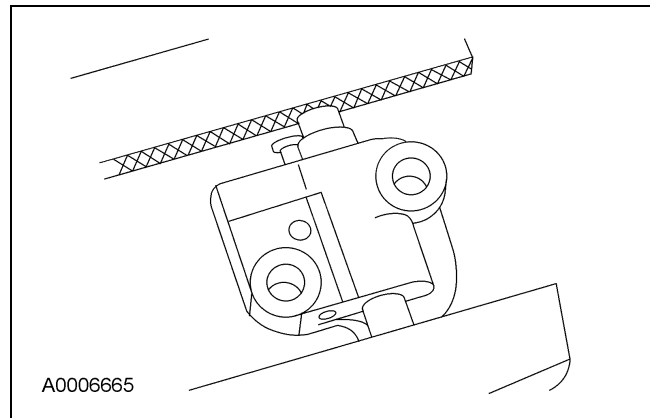

- NOTE:** LH shown, RH similar.  
Hold the chain tensioner ratchet lock mechanism away from the ratchet stem with a small pick.

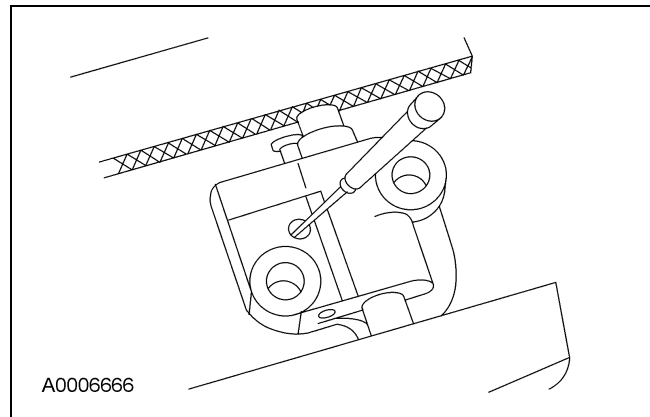

## IN-VEHICLE REPAIR (Continued)

4.  **CAUTION:** During tensioner compression, do not release the ratchet stem until the tensioner piston is fully bottomed in its bore or damage to the ratchet stem will result.

Slowly compress the timing chain tensioner.

5. Retain the tensioner piston with a 1.5 mm (0.06 in) wire or paper clip.

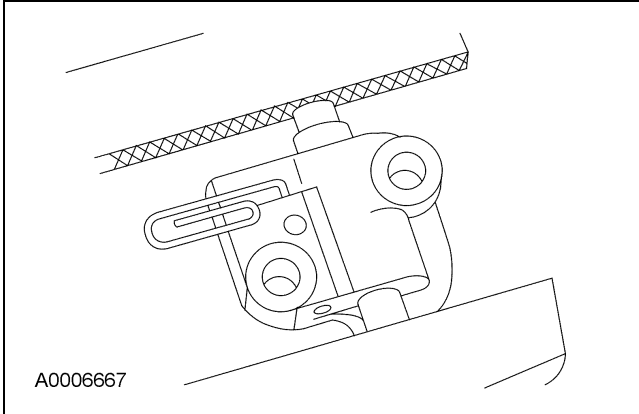

6. If timing marks in the timing chains are not evident, use a permanent-type marker to mark the crankshaft and camshaft timing marks on the LH and RH timing chains.
- 1 Mark any link to use as the crankshaft timing mark.
  - 2 Starting with the crankshaft timing mark, count 29 links and mark the link.
  - 3 Continue counting to 42 and mark the link.

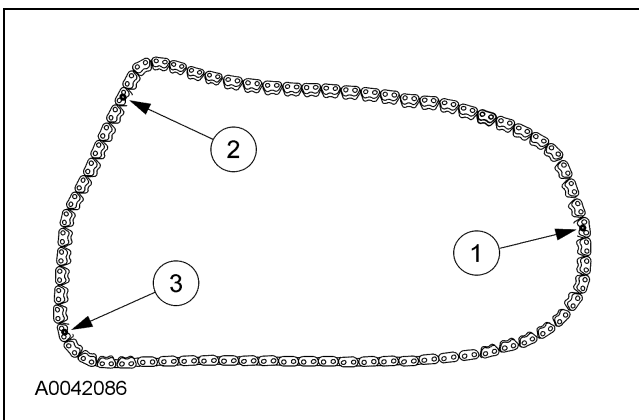

7. Position the LH timing chain and guide and install the bolts.
- Align the marks on the timing chain with the marks on the camshaft and crankshaft sprockets.

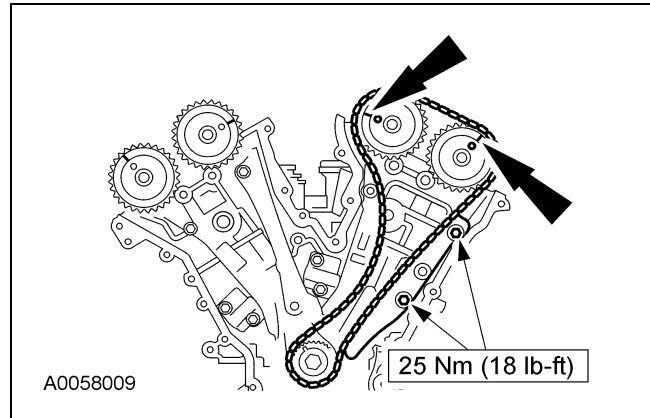

8. Install the LH timing chain tensioner and tensioner arm.

- 1 Install the tensioner arm.
- 2 Position the tensioner.
- 3 Install the bolts.

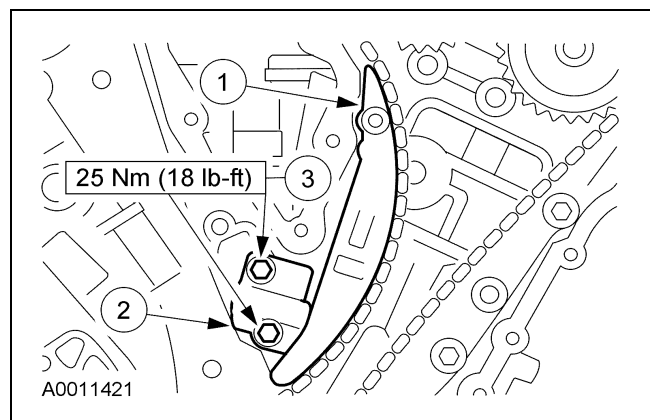

9. Install the crankshaft damper bolt and rotate the crankshaft clockwise 120 degrees until the crankshaft keyway is in the 3 o'clock position.

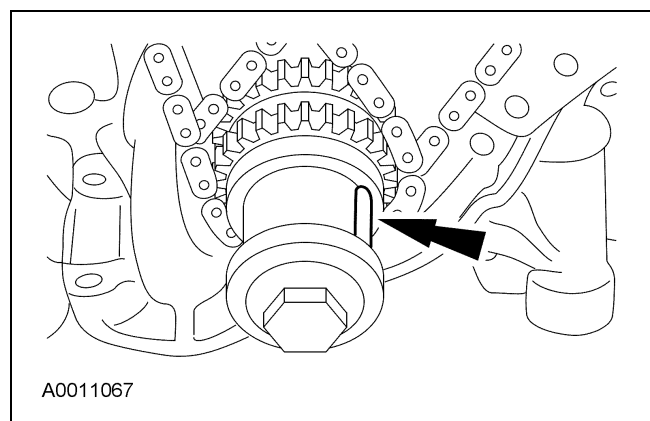

**IN-VEHICLE REPAIR (Continued)**

10. Verify that the RH camshafts are correctly positioned.

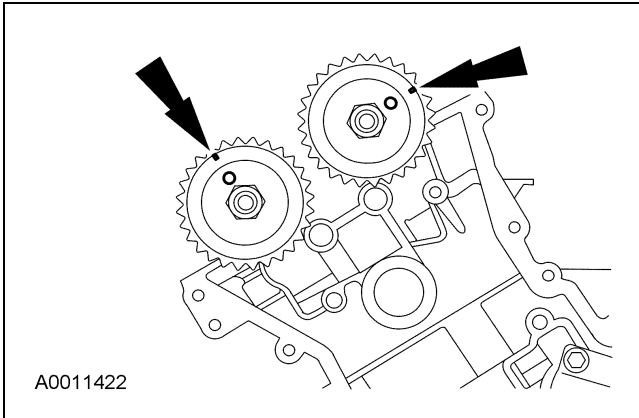

11. Position the RH timing chain and chain guide and install the bolts.

- Align the marks on the timing chain with the marks on the camshaft and crankshaft sprockets.

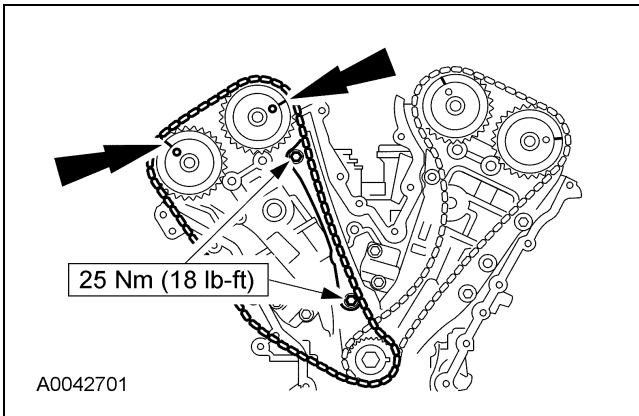

12. Install the RH timing chain tensioner and tensioner arm.

- 1 Install the tensioner arm.
- 2 Position the tensioner.
- 3 Install the bolts.

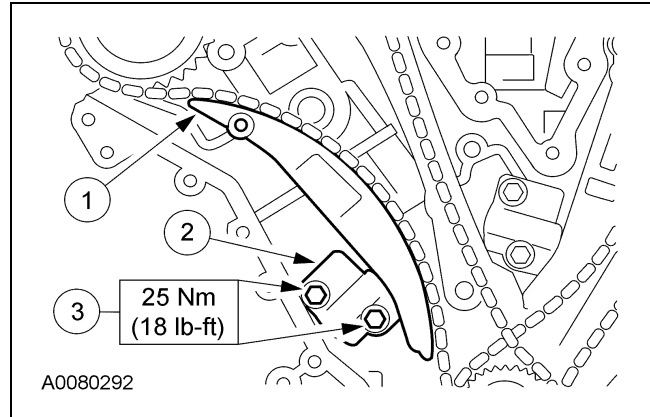

13. Remove the LH and RH timing chain tensioner piston retaining wires.

14. Rotate the crankshaft counterclockwise 120 degrees to top dead center (TDC)

**IN-VEHICLE REPAIR (Continued)**

15.  **CAUTION: Failure to verify correct timing drive component alignment will result in severe engine damage.**

Verify the timing with the following steps.

- 1 There should be 12 chain links between the front camshaft timing marks.
- 2 There should be 27 chain links between the camshaft and crankshaft timing marks.
- 3 There should be 30 chain links between the camshaft and crankshaft timing marks.

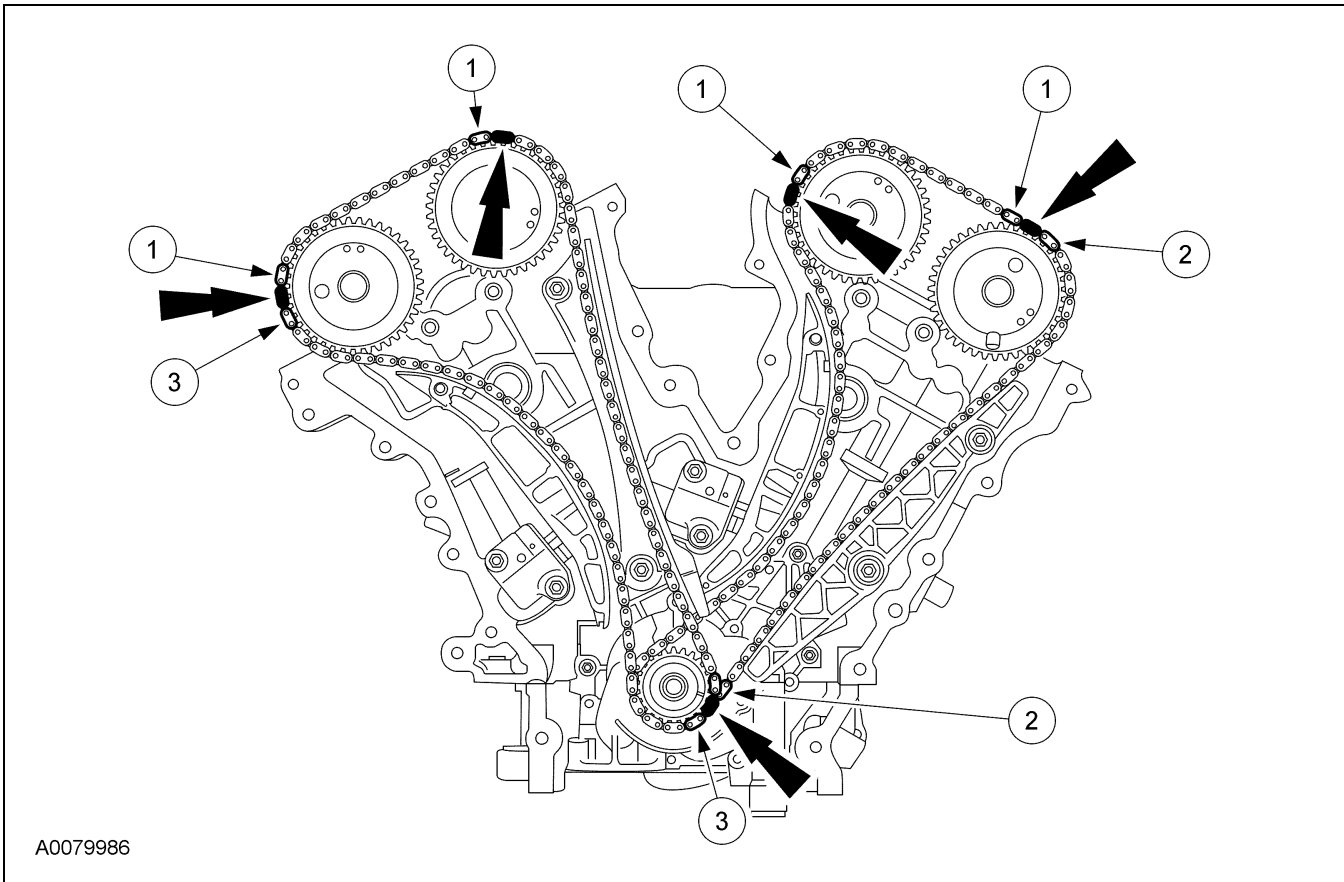

16. Remove the crankshaft damper bolt.

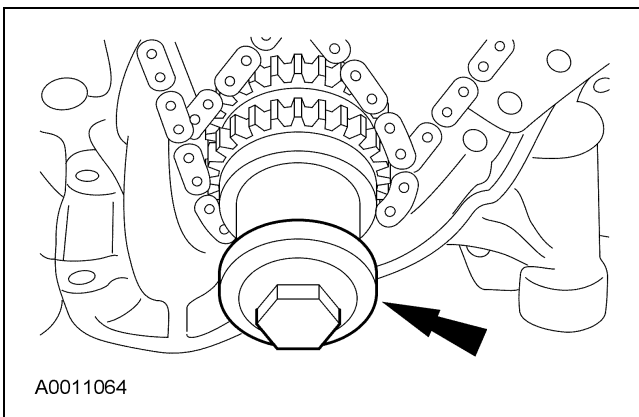

**IN-VEHICLE REPAIR (Continued)**

17. **NOTE:** LH shown, RH similar.

Install the LH and RH spark plugs.

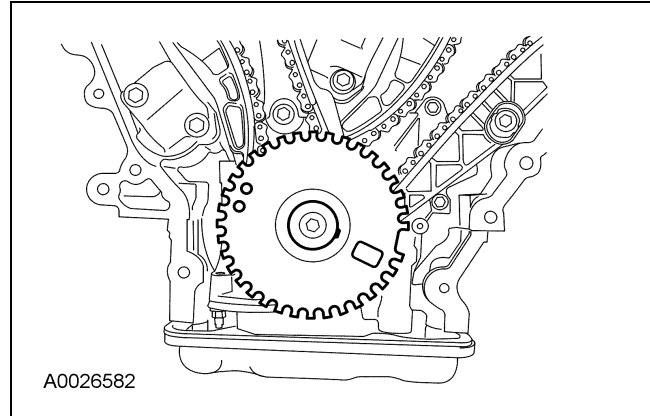
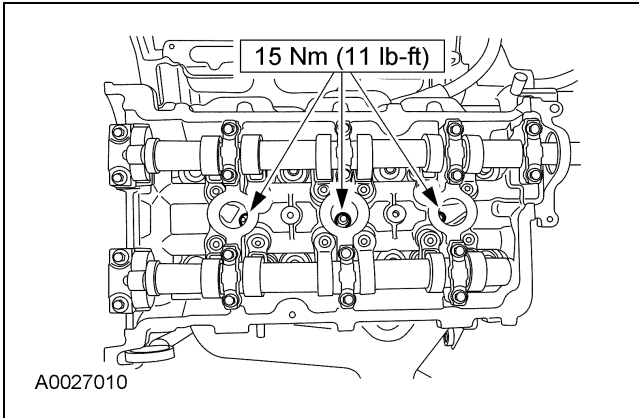

19. Install the engine front cover. For additional information, refer to Engine Front Cover in this section.

18. **⚠ CAUTION:** This pulse wheel is used with several different engines. Install the pulse wheel with the keyway in the slot stamped "30" or "30 RFF" only (orange in color).

Install the ignition pulse wheel.